

(1) Consider the electrical network below.

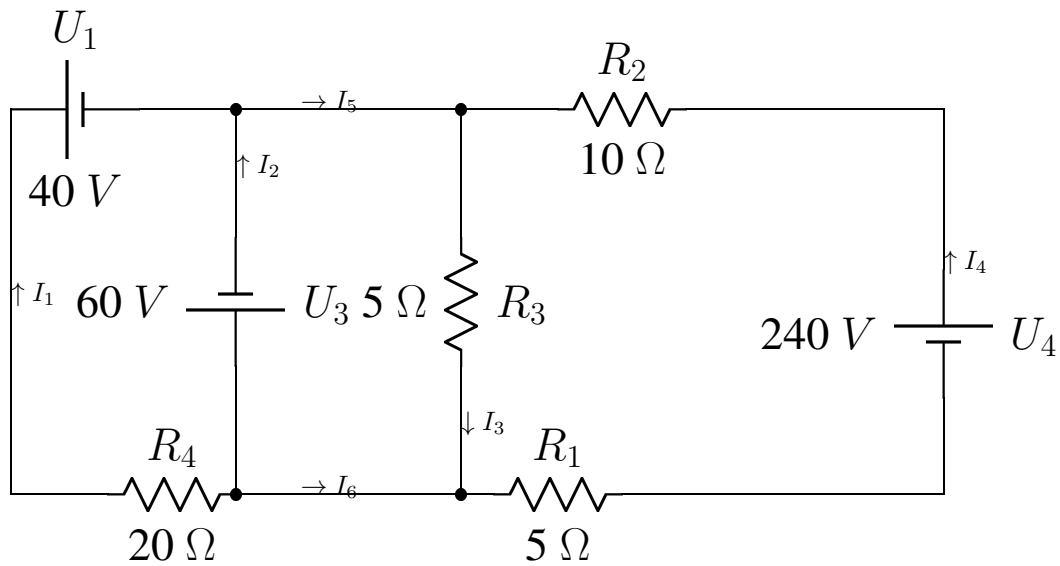

Recall that source of voltage  $\left| \begin{array}{c} | \\ | \\ | \end{array} \right|$  has the plus pole on the left and the minus pole on the right. So if you start at the left side, then the voltage has positive sign (voltage decrease), otherwise negative sign (voltage increase).

(a) (4 pts) If  $I_1, I_2, \dots, I_6$  denote the electric currents in amperes, directed as indicated, apply the junction rule to obtain a homogeneous system of linear equations describing the currents when resistors and sources of voltage are ignored. Solve the system.

(b) (3 pts) For every closed circuit in the network choose a direction (clockwise or counterclockwise). Indicate this direction clearly in the diagram above. Using Ohm's law and the circuit rule to find the remaining equations needed to describe the current.

(c) (1 pt) The equations in (a) and (b) form a linear system in the variables  $I_1, I_2, \dots, I_6$ . Find the currents in the circuit by solving the system.

**Solution:** (a) The junction rule gives that

$$\begin{array}{rcccc} I_1 & +I_2 & & & = & I_5 \\ I_1 & +I_2 & & & +I_6 & = & 0 \\ & & I_4 & +I_5 & & = & I_3 \\ & & I_3 & & +I_6 & = & I_4 \end{array}$$

and the corresponding system of homogeneous equations is

$$\begin{array}{rcccc} I_1 & +I_2 & & -I_5 & = & 0 \\ I_1 & +I_2 & & & +I_6 & = & 0 \\ & & -I_3 & +I_4 & +I_5 & = & 0 \\ & & I_3 & -I_4 & +I_6 & = & 0 \end{array}$$

We write down the coefficient matrix of the system and row-reduce :

$$\begin{bmatrix} 1 & 1 & 0 & 0 & -1 & 0 \\ 1 & 1 & 0 & 0 & 0 & 1 \\ 0 & 0 & -1 & 1 & 1 & 0 \\ 0 & 0 & 1 & -1 & 0 & 1 \end{bmatrix} \sim \begin{bmatrix} 1 & 1 & 0 & 0 & -1 & 0 \\ 0 & 0 & 0 & 0 & 1 & 1 \\ 0 & 0 & 1 & -1 & -1 & 0 \\ 0 & 0 & 1 & -1 & 0 & 1 \end{bmatrix} \sim \begin{bmatrix} 1 & 1 & 0 & 0 & -1 & 0 \\ 0 & 0 & 0 & 0 & 1 & 1 \\ 0 & 0 & 1 & -1 & -1 & 0 \\ 0 & 0 & 0 & 0 & 1 & 1 \end{bmatrix}$$

$$\sim \begin{bmatrix} 1 & 1 & 0 & 0 & -1 & 0 \\ 0 & 0 & 1 & -1 & -1 & 0 \\ 0 & 0 & 0 & 0 & 1 & 1 \\ 0 & 0 & 0 & 0 & 0 & 0 \end{bmatrix} \sim \begin{bmatrix} 1 & 1 & 0 & 0 & 0 & 1 \\ 0 & 0 & 1 & -1 & 0 & 1 \\ 0 & 0 & 0 & 0 & 1 & 1 \\ 0 & 0 & 0 & 0 & 0 & 0 \end{bmatrix}.$$

Thus, the general solution is

$$\begin{bmatrix} I_1 \\ I_2 \\ I_3 \\ I_4 \\ I_5 \\ I_6 \end{bmatrix} = \begin{bmatrix} -I_2 - I_6 \\ I_2 \\ I_4 - I_6 \\ I_4 \\ -I_6 \\ I_6 \end{bmatrix} = \begin{bmatrix} -s_1 - s_3 \\ s_1 \\ s_2 - s_3 \\ s_2 \\ -s_3 \\ s_3 \end{bmatrix} \quad (s_1, s_2, s_3 \text{ free parameters})$$

(b) We will go around each closed circuit in clockwise direction. This yields

$$\begin{aligned} 20I_1 &= -40 + 60 \\ 5I_3 &= -60 \\ -5I_3 - 5I_4 - 10I_4 &= -240 \end{aligned}$$

Equivalently,

$$I_1 = 1, \quad I_3 = -12, \quad 5I_3 + 15I_4 = 240, \text{ or } I_4 = \frac{1}{15}(240 + 60) = 20.$$

(c) We insert the values found in (b) into the equations of (a) and get the linear system

$$\begin{aligned} s_1 + s_3 &= -I_1 = -1 \\ s_2 - s_3 &= I_3 = -12 \\ s_2 &= I_4 = 20 \end{aligned}$$

Hence

$$s_3 = s_2 + 12 = 32, \quad s_1 = -1 - s_3 = -33,$$

and for all currents we get

$$I_1 = 1, \quad I_2 = -33, \quad I_3 = -12, \quad I_4 = 20, \quad I_5 = -32, \quad I_6 = 32.$$

**Marking:** (a) 2 pt for correct linear system, 2 pts for row-reduction, 1 pt for correct solution.

(2) Consider the following matrices

$$A = \begin{bmatrix} 1 & 2 & 3 \\ 2 & 1 & 4 \end{bmatrix}, \quad B = \begin{bmatrix} 1 & 0 \\ 2 & 1 \\ 3 & 2 \end{bmatrix}, \quad C = \begin{bmatrix} 1 \\ -3 \\ 5 \end{bmatrix}, \quad D = \begin{bmatrix} 3 & -2 \\ -2 & 3 \end{bmatrix}.$$

(a) (3 pts) Which of the following are defined? **Justify your answer!** Do not compute the matrix product.

$$AB, \quad BD, \quad DB, \quad AC, \quad B^2, \quad D^2.$$

(b) (2 pts) Calculate the following :

$$A^T B^T, \quad DD^T.$$

(c) (5 pts) Let  $X = \begin{bmatrix} a & b \\ c & d \end{bmatrix}$  be a  $2 \times 2$  matrix. Find necessary and sufficient conditions for  $a, b, c$  and  $d$  such that

$$XD = DX$$

where  $D$  is as above. Give an example of a matrix  $Y$  for which  $YD \neq DY$ , or explain why this is not possible.

**Solution:** (a) The product  $XY$ , where  $X$  is  $m \times n$  and  $Y$  is  $p \times q$ , is defined if and only if  $n = p$ .  
 $AB$  is defined since  $A$  is  $2 \times 3$  and  $B$  is  $3 \times 2$ .  
 $BD$ . Here  $B$  is  $3 \times 2$  and  $D$  is  $2 \times 2$ , hence the product is defined.  
 $DB$  is not defined since  $D$  is  $2 \times 2$  and  $B$  is  $3 \times 2$ .  
 $AC$  is defined :  $A$  is  $2 \times 3$  and  $C$  is  $3 \times 1$ .  
 $B^2$  is not defined since the number of rows of  $B$  is not equal to the number of columns of  $B$ .  
 $D^2$  is defined since the number of rows of  $D$  is equal to the number of columns of  $D$ .

(b)

$$A^T B^T = (BA)^T = \left( \left( \begin{bmatrix} 1 & 0 \\ 2 & 1 \\ 3 & 2 \end{bmatrix} \begin{bmatrix} 1 & 2 & 3 \\ 2 & 1 & 4 \end{bmatrix} \right)^T = \left( \begin{bmatrix} 1 & 2 & 3 \\ 4 & 5 & 10 \\ 7 & 8 & 17 \end{bmatrix} \right)^T = \begin{bmatrix} 1 & 4 & 7 \\ 2 & 5 & 8 \\ 3 & 10 & 17 \end{bmatrix}.$$

$$DD^T = \begin{bmatrix} 3 & -2 \\ -2 & 3 \end{bmatrix} \begin{bmatrix} 3 & -2 \\ -2 & 3 \end{bmatrix} = \begin{bmatrix} 13 & -12 \\ -12 & 13 \end{bmatrix}.$$

(c) We let  $X$  be an arbitrary matrix :  $X = \begin{bmatrix} a & b \\ c & d \end{bmatrix}$  and calculate

$$\begin{aligned} XD &= DX \\ \Leftrightarrow \begin{bmatrix} a & b \\ c & d \end{bmatrix} \begin{bmatrix} 3 & -2 \\ -2 & 3 \end{bmatrix} &= \begin{bmatrix} 3 & -2 \\ -2 & 3 \end{bmatrix} \begin{bmatrix} a & b \\ c & d \end{bmatrix} \\ \Leftrightarrow \begin{bmatrix} 3a - 2b & -2a + 3b \\ 3c - 2d & -2c + 3d \end{bmatrix} &= \begin{bmatrix} 3a - 2c & 3b - 2d \\ -2a + 3c & -2b + 3d \end{bmatrix} \end{aligned}$$

By definition of equality for matrices, this is equivalent to

$$\begin{aligned} 3a - 2b &= 3a - 2c, & -2a + 3b &= 3b - 2d, \\ 3c - 2d &= -2a + 3c, & -2c + 3d &= -2b + 3d. \end{aligned}$$

From the first equation we get  $b = c$ , and from the second  $a = d$ . Conversely, if

$$b = c, \quad a = d,$$

then the equations above are fulfilled. Hence the product  $DX$  is equal to the product  $XD$  if and only if  $X$  is of the form

$$\begin{bmatrix} a & b \\ b & a \end{bmatrix}$$

for arbitrary real number  $a$  and  $b$ .An example for a matrix  $Y$  such that  $YD \neq DY$  is given by the matrix  $Y = \begin{bmatrix} 1 & 0 \\ 0 & 0 \end{bmatrix}$ . We have

$$\begin{bmatrix} 3 & -2 \\ -2 & 3 \end{bmatrix} \begin{bmatrix} 1 & 0 \\ 0 & 0 \end{bmatrix} = \begin{bmatrix} 3 & 0 \\ -2 & 0 \end{bmatrix}$$

and

$$\begin{bmatrix} 1 & 0 \\ 0 & 0 \end{bmatrix} \begin{bmatrix} 3 & -2 \\ -2 & 3 \end{bmatrix} = \begin{bmatrix} 3 & -2 \\ 0 & 0 \end{bmatrix}.$$

**Marking:** (c) Characterization of  $XD = DX$  : 4 pts, example 1 pt.(3) (8 pts) Determine whether each of the following vectors  $V_1, \dots, V_4$  is a linear combination of the vectors

$$X_1 = [1 \ 2 \ 0]^T \quad \text{and} \quad X_2 = [2 \ 0 \ -1]^T.$$

(a)  $V_1 = [2 \ 0 \ -1]^T$ ;

(b)  $V_2 = [0 \ 0 \ 0]^T$ ;

(c)  $V_3 = [0 \ 4 \ 1]^T$ ;

(d)  $V_4 = [2 \ 2 \ -1]^T$ .

**Solution:** (a) Since  $V_1 = 0X_1 + 1X_2$ ,  $V_1$  is a linear combination of  $X_1$  and  $X_2$ .(b) Since  $V_2 = 0X_1 + 0X_2$ ,  $V_2$  is a linear combination of  $X_1$  and  $X_2$ .(c) Suppose  $V_3$  is a linear combination of  $X_1$  and  $X_2$ . Thus  $V_3 = [0 \ 4 \ 1]^T = xX_1 + yX_2 = [x + 2y \ 2x \ -y]^T$ . Thus we get a linear system :

$$x + 2y = 0, \quad 2x = 4, \quad -y = 1.$$

This system has the unique solution  $x = 2, y = -1$ . Hence,

$$V_3 = 2X_1 + (-1)X_2,$$

and  $V_3$  is a linear combination of  $X_1$  and  $X_2$ .

(d) We proceed as in (c). Let  $V_4 = [2 \ 2 \ -1]^T = xX_1 + yX_2 = [x + 2y \ 2x \ -y]^T$ . The linear system now becomes :

$$x + 2y = 2, \quad 2x = 2, \quad -y = -1.$$

From the last two equations, we get  $x = y = 1$ . However,  $x = y = 1$  does not satisfy the first equation. Hence, this system does not have a solution. Therefore  $V_4$  is not a linear combination of  $X_1$  and  $X_2$ .

**Marking:** each part has 2 pts.

(4) (4 pts) In the formula below replace  $\alpha$  by the last digit of your student number and determine  $A$  :

$$\left(3A^T - \begin{bmatrix} 1 & \alpha & -2 \\ -4 & 5 & \alpha - 2 \end{bmatrix}\right)^T = \begin{bmatrix} -4 & 3 \\ 2 & \alpha + 3 \\ -2 & 6 \end{bmatrix} + 3 \begin{bmatrix} 7 & -5 & 4 \\ 9 & 12 & \alpha \end{bmatrix}^T.$$

**Solution:** We calculate the both sides of the equation, using the rules of Theorem 2 in §2.1 :

$$\begin{aligned} \left(3A^T - \begin{bmatrix} 1 & \alpha & -2 \\ -4 & 5 & \alpha - 2 \end{bmatrix}\right)^T &= 3(A^T)^T - \begin{bmatrix} 1 & \alpha & -2 \\ -4 & 5 & \alpha - 2 \end{bmatrix}^T = 3A - \begin{bmatrix} 1 & -4 \\ \alpha & 5 \\ -2 & \alpha - 2 \end{bmatrix} \\ \begin{bmatrix} -4 & 3 \\ 2 & \alpha + 3 \\ -2 & 6 \end{bmatrix} + 3 \begin{bmatrix} 7 & -5 & 4 \\ 9 & 12 & \alpha \end{bmatrix}^T &= \begin{bmatrix} -4 & 3 \\ 2 & \alpha + 3 \\ -2 & 6 \end{bmatrix} + 3 \begin{bmatrix} 7 & 9 \\ -5 & 12 \\ 4 & \alpha \end{bmatrix} \\ &= \begin{bmatrix} -4 & 3 \\ 2 & \alpha + 3 \\ -2 & 6 \end{bmatrix} + \begin{bmatrix} 21 & 27 \\ -15 & 36 \\ 12 & 3 \cdot \alpha \end{bmatrix} = \begin{bmatrix} 17 & 30 \\ -13 & \alpha + 39 \\ 10 & 6 + 3\alpha \end{bmatrix} \end{aligned}$$

Hence

$$3A - \begin{bmatrix} 1 & -4 \\ \alpha & 5 \\ -2 & \alpha - 2 \end{bmatrix} = \begin{bmatrix} 17 & 30 \\ -13 & \alpha + 39 \\ 10 & 6 + 3\alpha \end{bmatrix}$$

Therefore

$$\begin{aligned} 3A &= \begin{bmatrix} 17 & 30 \\ -13 & \alpha + 39 \\ 10 & 6 + 3\alpha \end{bmatrix} + \begin{bmatrix} 1 & -4 \\ \alpha & 5 \\ -2 & \alpha - 2 \end{bmatrix} = \begin{bmatrix} 18 & 26 \\ \alpha - 13 & \alpha + 44 \\ 8 & 4(\alpha + 1) \end{bmatrix} \\ A &= \frac{1}{3} \begin{bmatrix} 18 & 26 \\ \alpha - 13 & \alpha + 44 \\ 8 & 4(\alpha + 1) \end{bmatrix} = \begin{bmatrix} 6 & \frac{26}{3} \\ \frac{1}{3}(\alpha - 13) & \frac{1}{3}(\alpha + 44) \\ \frac{8}{3} & \frac{4}{3}(\alpha + 1) \end{bmatrix}. \end{aligned}$$

- (5) Let  $T_1 : \mathbb{R}^2 \rightarrow \mathbb{R}^2$  and  $T_2 : \mathbb{R}^2 \rightarrow \mathbb{R}^2$  be the matrix transformations induced by the matrices  $M_1$  and  $M_2$  respectively, where

$$M_1 = \begin{bmatrix} -1 & 0 \\ 0 & 1 \end{bmatrix} \quad \text{and} \quad M_2 = \begin{bmatrix} 0 & -1 \\ -1 & 0 \end{bmatrix}.$$

(a) (4 pts) Find the general formula for the transformations  $T_1$  and  $T_2$ , and determine the geometric meaning of  $T_1$  and  $T_2$ .

(b) (3 pts) Find the matrix of the composition  $T_3 = T_2 \circ T_1$ , and determine the geometric meaning of the transformation  $T_3$ .

**Solution:** (a) (2 pts) Let  $X = [x \ y]^T$  be an arbitrary vector in  $\mathbb{R}^2$ . Thus  $T_1$  has the general formula  $T_1 X = [-x \ y]^T$ . It is the reflection about the  $y$ -axis.

We proceed in the same way for  $T_2$ . For an arbitrary  $X = [x \ y]^T \in \mathbb{R}^2$  we get  $T_2 X = [-y \ -x]^T$ . Hence  $T_2$  is the reflection about the line  $y = -x$ .

(b) The matrix of  $T_3 = T_2 \circ T_1$  is the matrix product

$$M_2 M_1 = \begin{bmatrix} -1 & 0 \\ 0 & 1 \end{bmatrix} \begin{bmatrix} 0 & -1 \\ -1 & 0 \end{bmatrix} = \begin{bmatrix} 0 & -1 \\ 1 & 0 \end{bmatrix}$$

For  $X = [x \ y]^T$  we get  $T_3 X = [-y \ x]^T$ . This transformation is the counterclockwise rotation through an angle  $\pi/2$ .

**Marking:** (a) 2 pts for each part (1 pt for the correct formula in each part). (b) 2 pts for the matrix, and 1 pt for the correct interpretation.

- (6) (a) (3 pts) Suppose  $A$  is a  $3 \times 5$ -matrix of rank 3. Is the linear system  $AX = B$  consistent for every  $B \in \mathbb{R}^3$ ? If yes, explain why. If no, provide a concrete counter-example (concrete = with numbers).

**Solution:** The augmented matrix  $[A|B]$  has size  $3 \times 6$ , its rank is therefore  $\leq 3$ . Any row-echelon form of  $[A|B]$  has the form  $[A'|B']$  where  $A'$  is a row-echelon form of  $A$ . Since  $A$  has rank 3, there are 3 leading 1's in  $A'$ . Thus  $[A|B]$  has rank  $\geq 3$ . It follows that  $\text{rank}[A|B] = 3 = \text{rank } A$ , and therefore  $AX = B$  is solvable for any  $B$ .

**Marking:** (a) 1pt for correct answer, 2 pts for correct justification

(b) (3 pts) Suppose the homogeneous linear system  $AX = 0$  has a nontrivial solution. If  $AX = B$  is consistent, is it uniquely solvable? Justify your answer!

**Solution:** Since  $AX = 0$  has a nontrivial solution  $X_1$ , the linear system  $AX = 0$  has infinitely many solutions, namely  $tX_1$  for any scalar  $t \in \mathbb{R}$ . Let  $Y$  be a solution of  $AX = B$ . Then, by Theorem 1 in §2.2,  $Y + tX_1$  is a solution of  $AX = B$ . So  $AX = B$  has infinitely many solutions: It is not uniquely solvable.

**Marking:** (a) 1pt for correct answer, 2 pts for correct justification